

Customer Name	Standard specification	FUJITSU MEDIA DEVICES LIMITED	
System	EGSM Rx (50/50)	DATE	May 22, 2003
FMD Part Number	FAR-F5CQ-942M50-B25A	Version 4.0	

**Table 1. Electrical specifications**

Passband: 925 ~ 960 MHz						
Item	Condition	Specification			Unit	Remark
		Min.	Typ.	Max.		
Insertion loss	925 -960 MHz	-	2.3	2.6	dB	+25+/-2°C
		-	-	3.3	dB	
Ripple	925 -960 MHz	-	0.9	1.6	dB	+25+/-2°C
		-	-	1.8	dB	
Absolute attenuation	D.C. -880 MHz	40	53	-	dB	
	880-905 MHz	25	39	-	dB	
	905-915 MHz	18	30	-	dB	
	980-1025 MHz	23	30	-	dB	
	1025-2000 MHz	35	50	-	dB	
	2000-3000 MHz	30	46	-	dB	
	3000-6000 MHz	25	40	-	dB	
Input VSWR	Unbalance	-	1.7	2.1	-	
Output VSWR	Balance	-	1.7	2.1	-	
Amplitude balance	925 -960 MHz	-1.0	-	+1.0	dB	
Phase balance	925 -960 MHz	170	-	190	deg.	
Input impedance	Unbalance	50			ohm	
Output impedance	Balance	50			ohm	
Input power	880 -915 MHz	+13			dBm	1/4 duty
Operating temperature		-30 to +85			°C	
Device size		2.5 x 2.0. x 1.0max.			mm	

Customer Name	Standard specification	FUJITSU MEDIA DEVICES LIMITED	
System	EGSM Rx (50/50)	DATE	May 22, 2003
FMD Part Number	FAR-F5CQ-942M50-B25A	Version 4.0	

● **Dimensions**

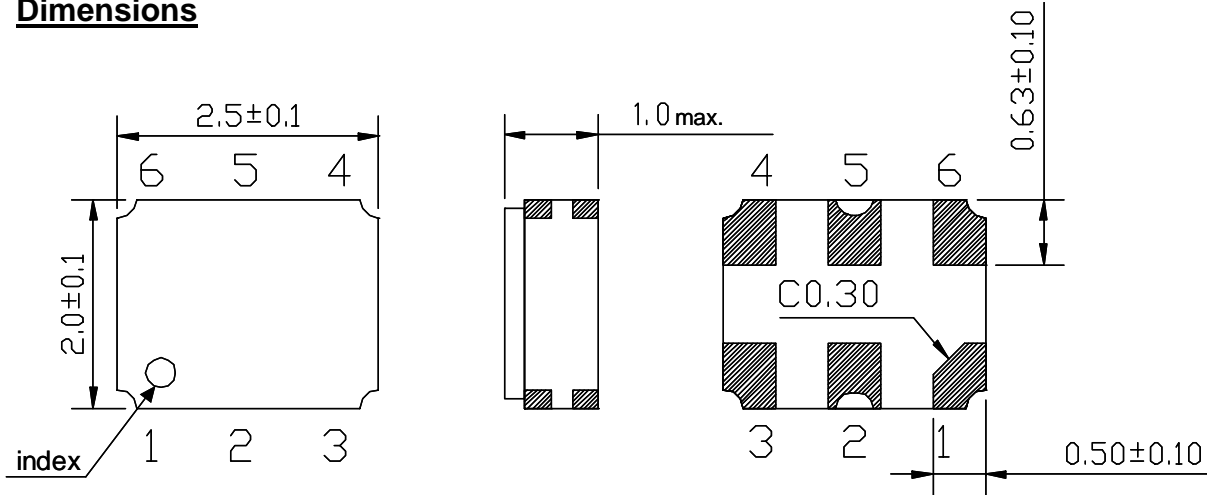


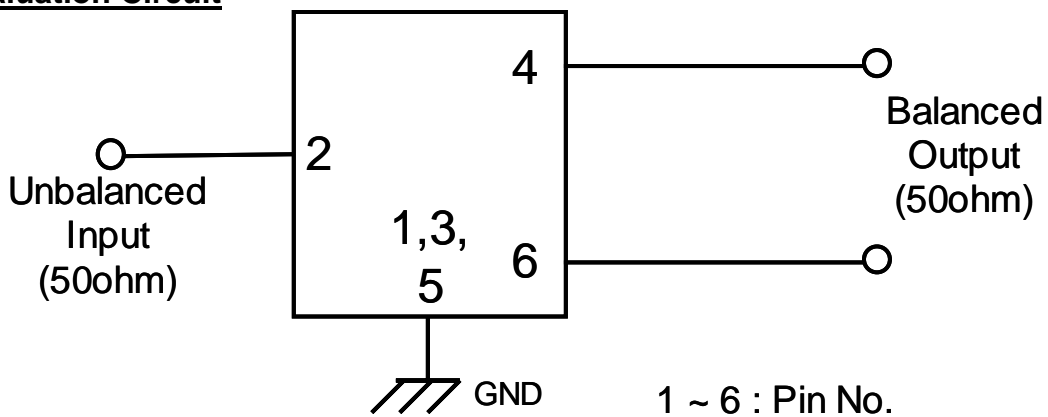
Fig.1

Unit: mm

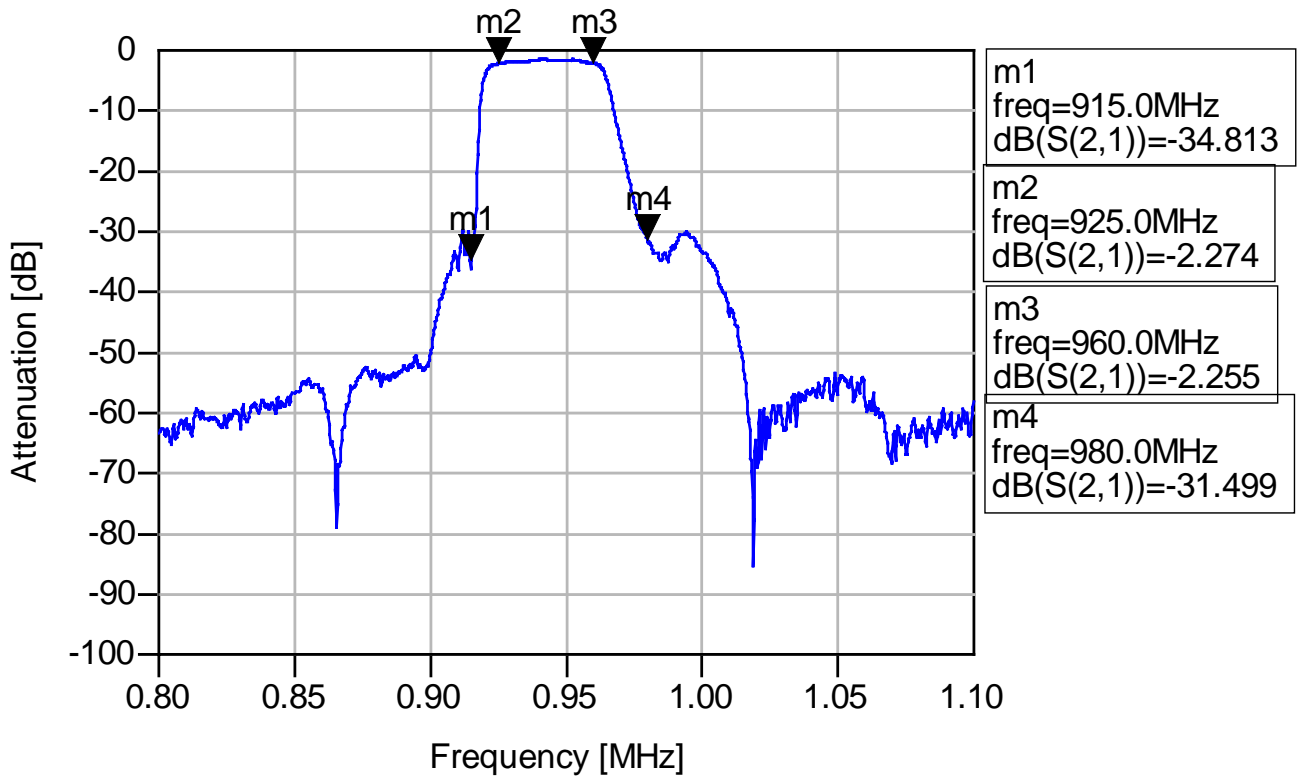
● **Pin Configuration**

Pin No.	Symbol	Function
1	GND	Ground
2	IN	Unbalanced pin
3	GND	Output
4	OUT	Balanced pin
5	GND	Ground
6	OUT	Balanced pin

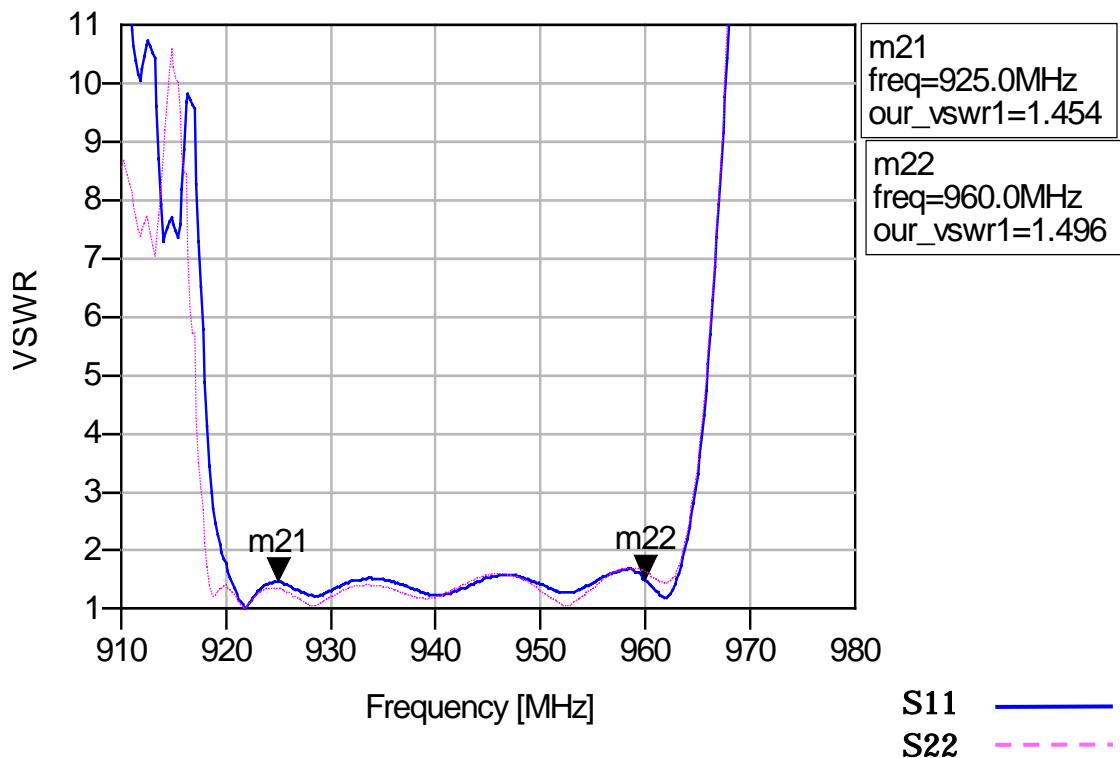
● **Evaluation Circuit**



Customer Name	<b>Standard specification</b>	FUJITSU MEDIA DEVICES LIMITED	
System	EGSM Rx (50/50)	DATE	May 22, 2003
FMD Part Number	FAR-F5CQ-942M50-B25A	Version 4.0	

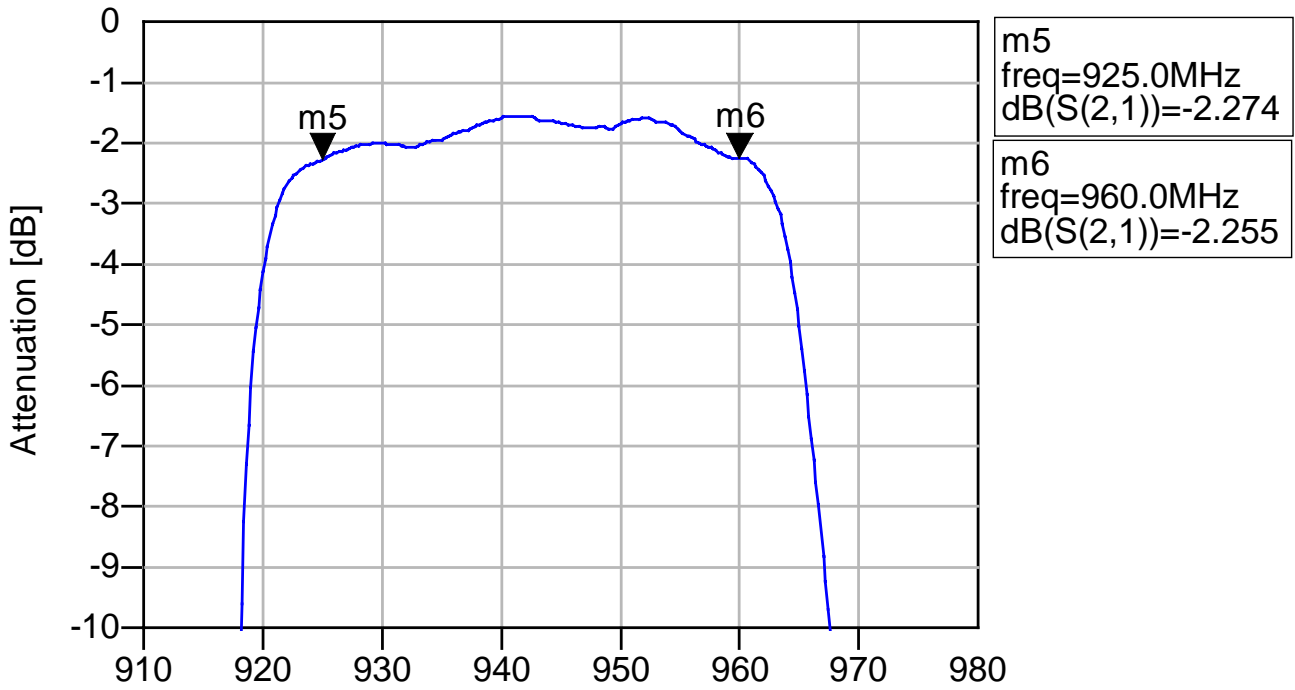


**Fig.1 Pass-band Characteristics**

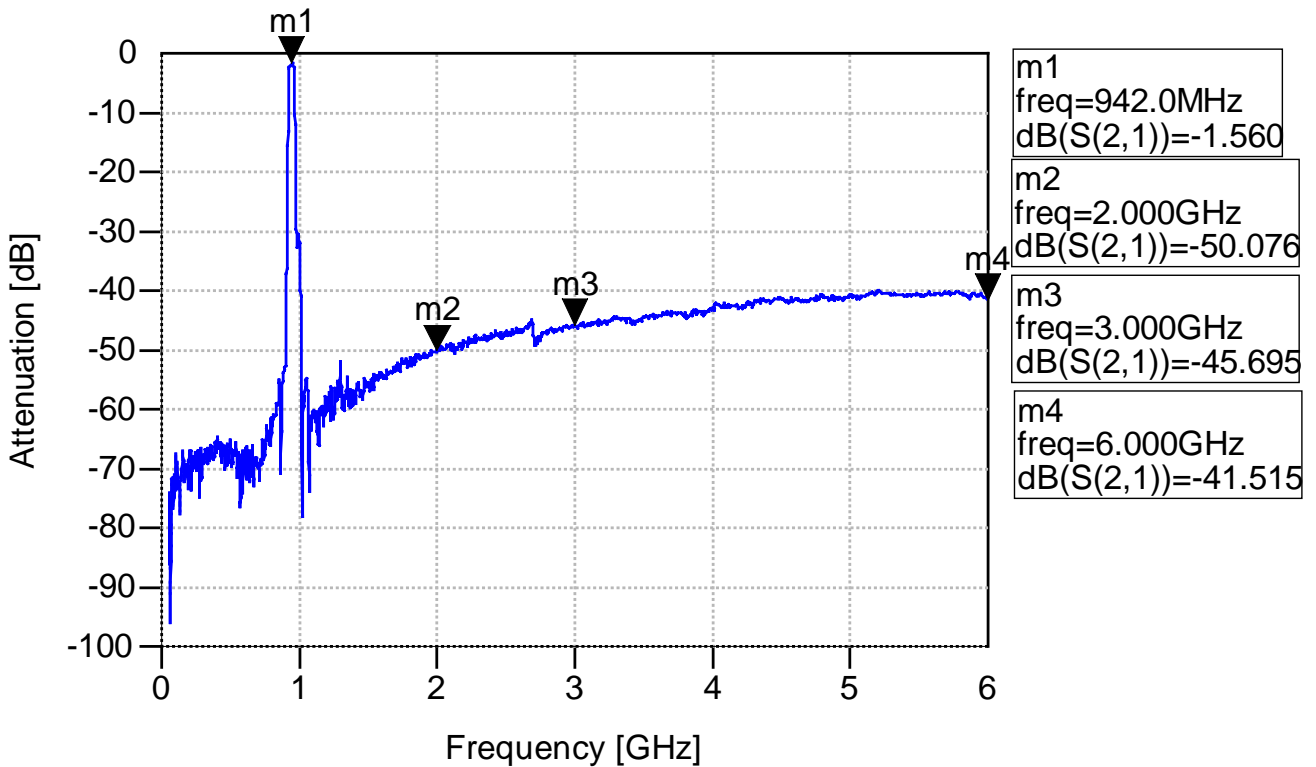


**Fig.2 VSWR**

Customer Name	Standard specification	FUJITSU MEDIA DEVICES LIMITED	
System	EGSM Rx (50/50)	DATE	May 22, 2003
FMD Part Number	FAR-F5CQ-942M50-B25A	Version 4.0	



Frequency [MHz]  
**Fig.3 In-band Characteristics**



Frequency [GHz]  
**Fig.4 Wide-band Characteristics**

Customer Name	Standard specification	FUJITSU MEDIA DEVICES LIMITED	
System	EGSM Rx (50/50)	DATE	May 22, 2003
FMD Part Number	FAR-F5CQ-942M50-B25A	Version 4.0	

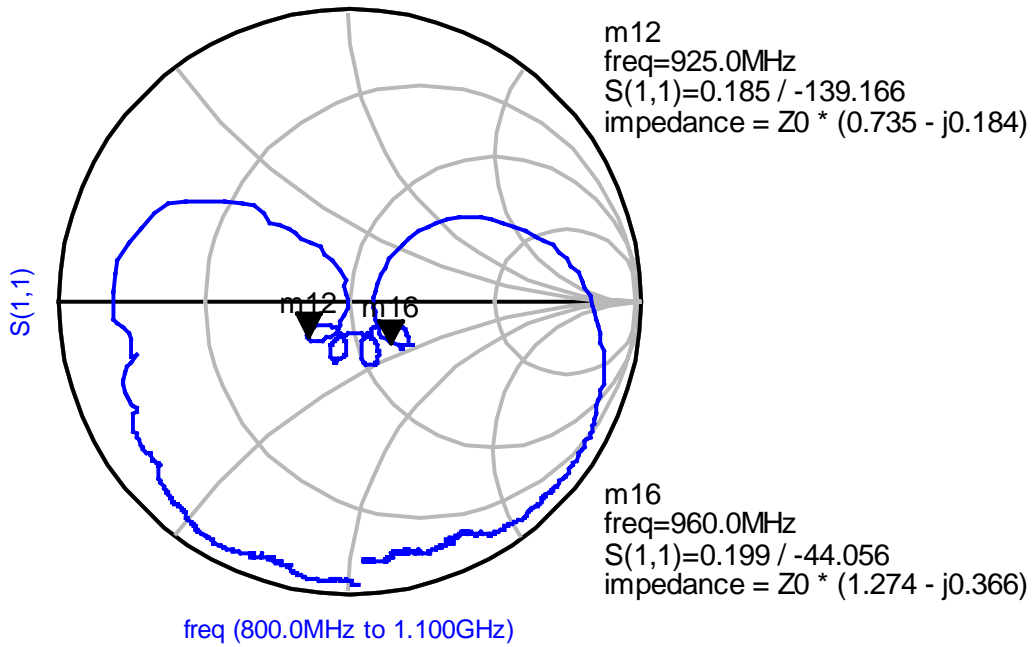


Fig.5 S11

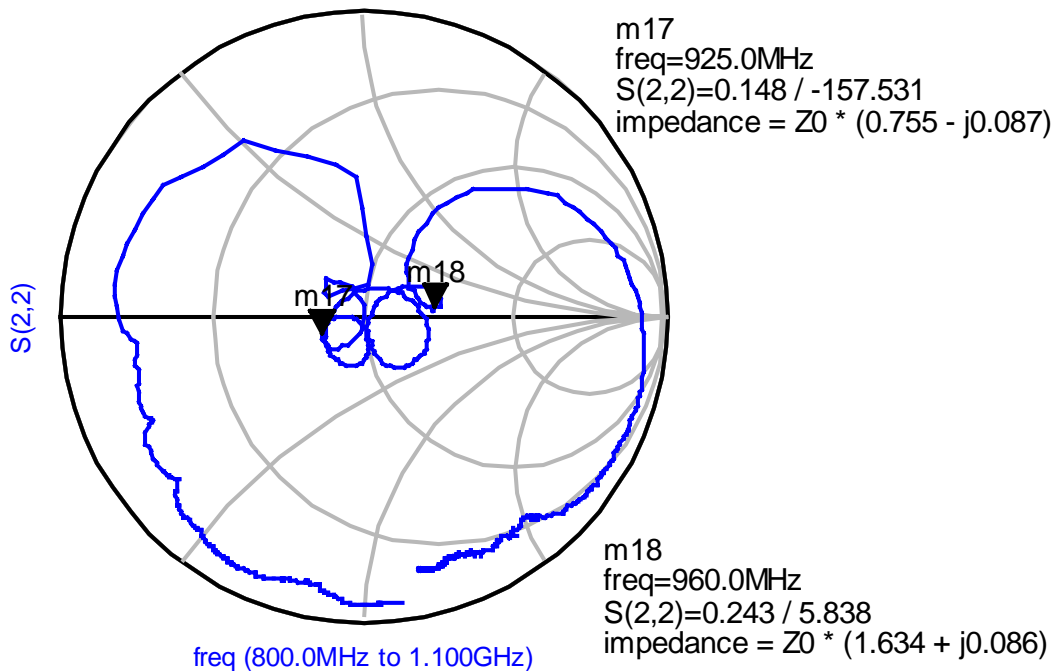
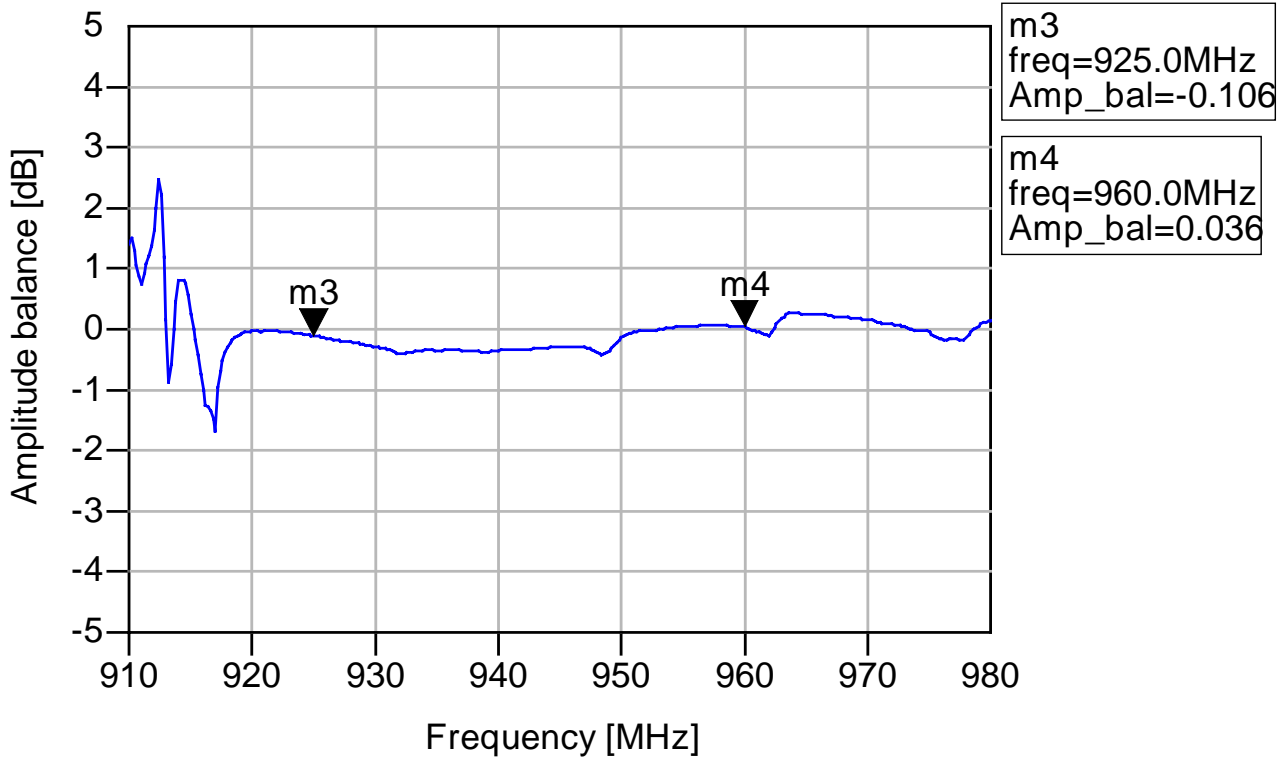
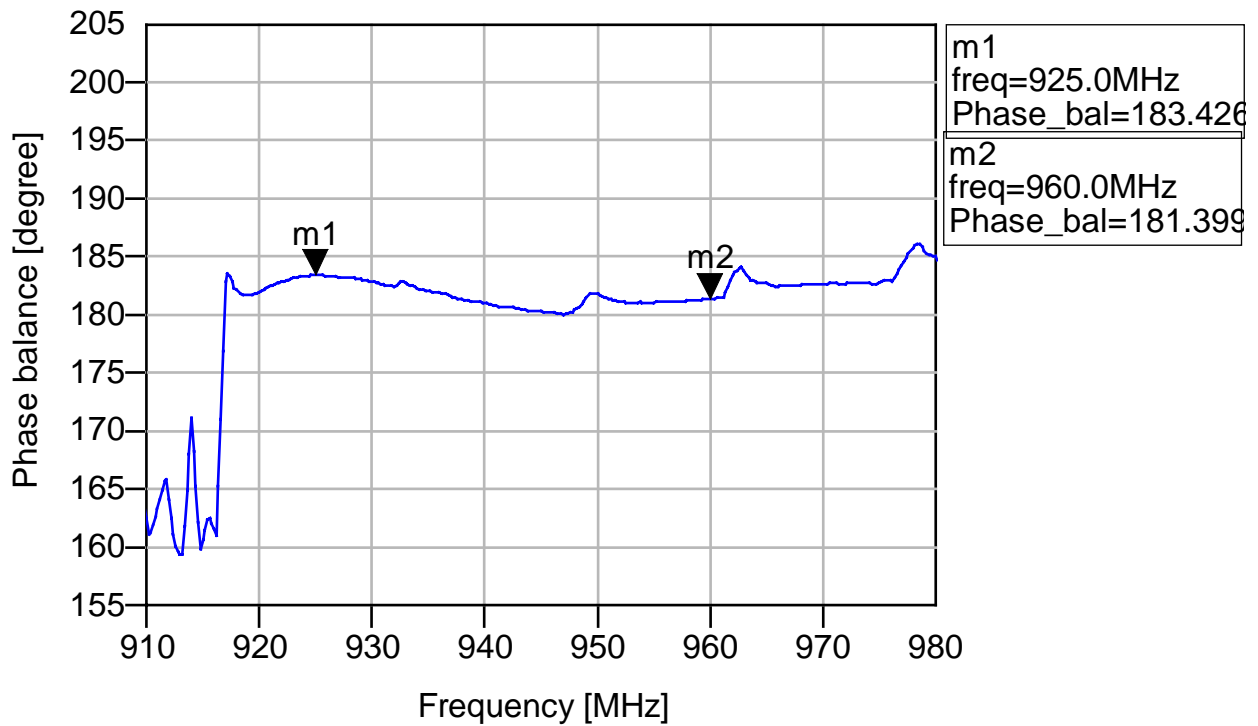


Fig.6 S22

Customer Name	<b>Standard specification</b>	FUJITSU MEDIA DEVICES LIMITED	
System	EGSM Rx (50/50)	DATE	May 22, 2003
FMD Part Number	FAR-F5CQ-942M50-B25A	Version 4.0	



**Fig.7 Amplitude balance**



**Fig.8 Phase balance**