

*Tape & Reel Specification of
1.4 x 1.0mm CSSD Filter*

Specification of Tape

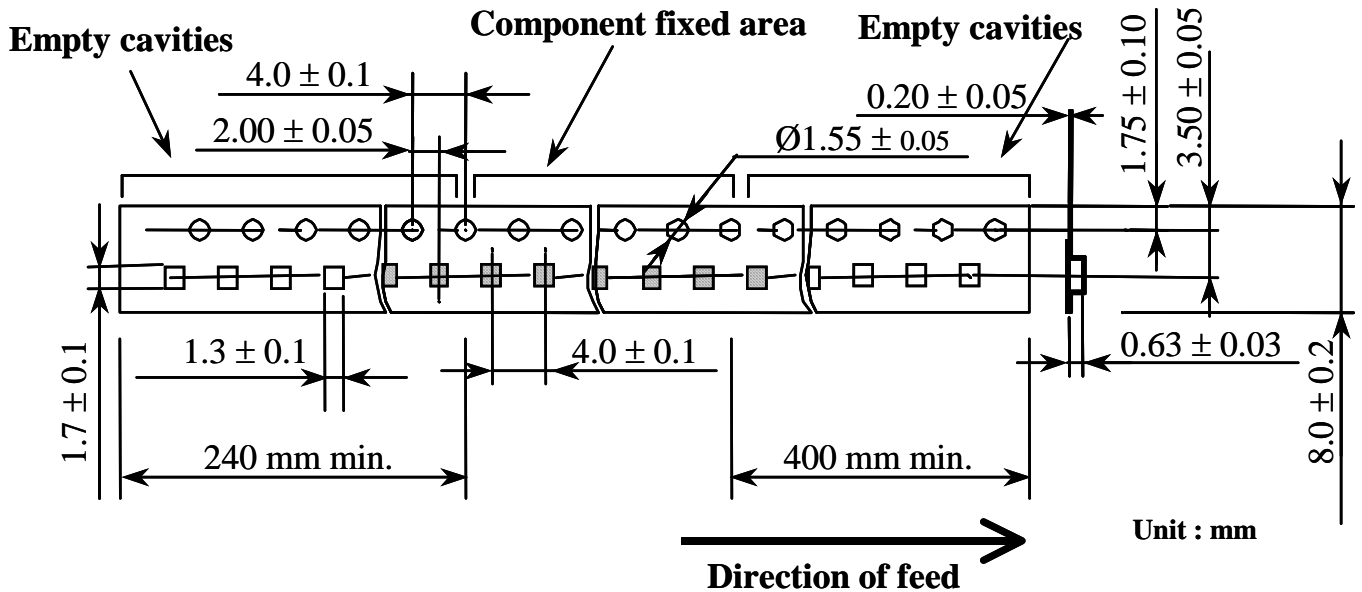

Material of Tape (Conductive material)

Tape : Polyethylene terephthalate or Polycarbonate

Top cover tape : Polyester

Peel strength of top cover tape

In case of 8mm width tape

Peel off by the force of 0.1 N to 1.0 N under the condition at the right

In case of 12mm to 56mm width tape

Peel off by the force of 0.1 N to 1.3 N under the condition at the right

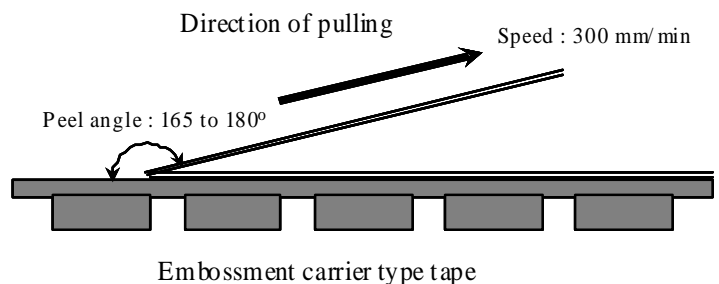

Specification of Reel

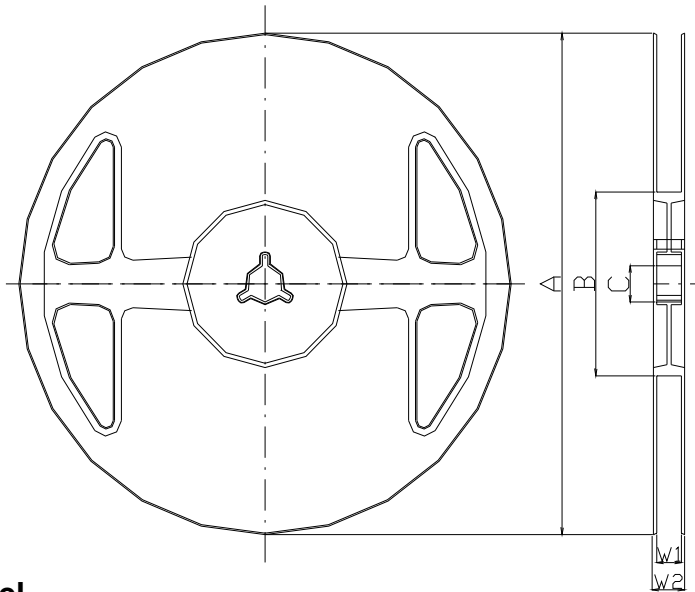

Materials of Reel

Material : Polystyrene + Carbon

Characteristics : Conforms to EIAJ-ET-7200A

Color : Black

Unit : mm

Code	Quantity	A	B	C	W1	W2
Z	3000 pcs.	$\phi 180.0 +0.0/-1.5$	$\phi 66.0 +/-0.5$	$\phi 13.0 +/-0.2$	$9.0 +1.0/-0.0$	$11.4 +/-1.0$

Bar code label sticking and winding Method

